



DURA.PC RANGE

PROFESSIONAL RENOVATION AND CONSTRUCTION

THE ALL-ROUND SOLUTION FOR
ACCESSIBLE SEWER SYSTEMS



FULL & PARTIAL RENOVATION

Sewer systems are as complex as the cities they drain. Old, brick sewers are usually the most complex. They form the backbone of the sewer network – and at the same time are increasingly in need of renovation. On the section of pipes to be renovated, one often encounters changes in cross-section, curves and bends with different radiuses. In environments like this, with changing geometries, the

multi-modular DURA. PC system – made of highly resistant polymer concrete, which can be formed into practically any shape during production – proves its worth. The molded parts can be adapted to suit the local conditions in many different ways. What's more, the optimal bend flexibility of the elements can be produced without great effort using an angle.

SEWER RENOVATION. KORROSIONSSCHUTZ FÜR GERINNE ODER GASRAUM.



A common example of sewer renovation is the lining of the invert with thin-walled, corrosion-resistant shells. This form of rehabilitation is particularly suitable for sewers with right angles or even acute angles in their cross-section. The renovation profiles are first joined together in the sewer and then bonded in place. In this way, the elements can be brought into the sewer through narrow manholes without excavation pits.

The bonding of our DURA.PC elements is straightforward and offers secure connections over the entire service life. If required, the arch of the sewer can also be lined. For partial renovations, a wide choice of standard elements is available, depending on the individual application. If an appropriate element is not available, a tailor-made solution can be developed at any time together with our experts.



FOR SEWERS AND MANHOLES

MANHOLE RENOVATION. SYSTEMATICALLY REFURBISHED.



As a rule, manhole renovation with our DURA.PC takes place in two steps. First, the base of the shaft is restored with specially cut-to-fit half shells and prefabricated polymer concrete berm plates. The rising manhole section is lined with corrosion-resistant elements, bonded into rings inside the shaft. The thin walls allowed by the properties of the material are particularly advantageous, allowing a maximum of free space to be retained. We are happy to advise you when it comes to choosing the right elements for your renovation plans.

COMPLETE SEWER RENOVATION. RESTORATION AND OPTIMIZATION.



For extensively damaged sewers, a complete renovation is necessary, but this can also be done to improve a new pipe. Two methods are available: pipe-segment lining and single-pipe lining.

In both cases, the new sewer is constructed inside the existing one, with which it forms a strong and durable connection: the components, once they have been fitted and bonded together, are cemented to the old sewer with free-flowing mortar. No hollow space remains between them; instead, an inseparable unit consisting of the old sewer and the new sewer is created. With this renovation solution, the service life of the old sewer can be extended considerably.

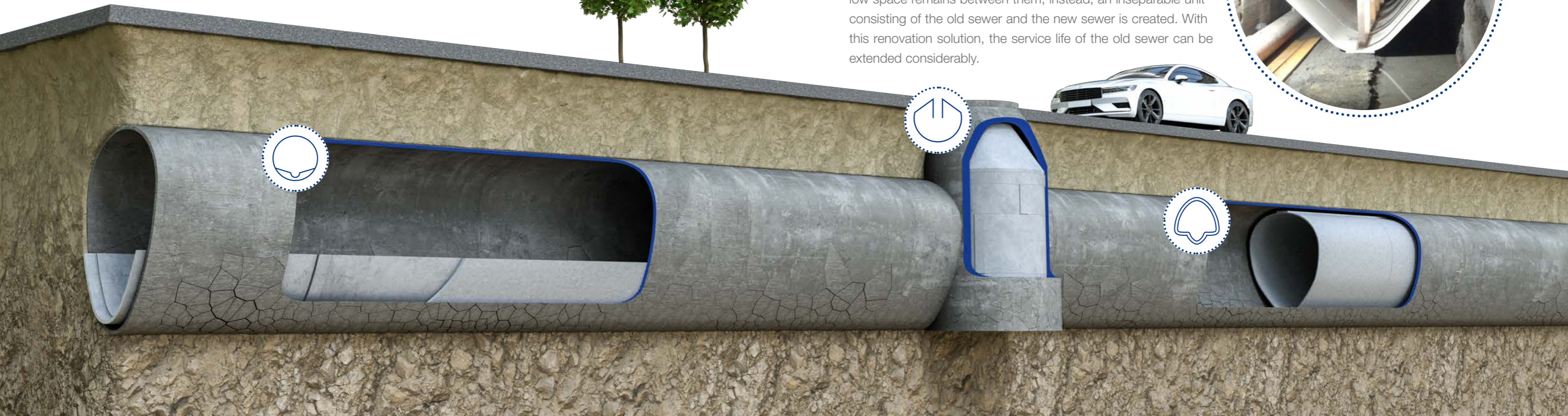

WHY DURA.PC?

DURA.PC elements are cast from polymer concrete, a material made of quartz of different grain sizes in a polyester resin composite. This composition makes the material extremely stable, robust and long-lived.

The outstanding properties of the material enable it to be used in areas with the highest requirements in terms of mechanical properties, abrasion resistance and chemical resistance.

Components made of polymer concrete have a higher mechanical flexural strength, better wear characteristics and higher chemical resistance compared to classical concrete. Polymer concrete is therefore the ideal building material for the renovation of sewers and manholes, winning users over with its exceptional durability and long service life.

This modern material is characterized by a flawless ecological balance through resource-saving production and environmentally friendly disposal and recycling. Polymer concrete can be disposed of as normal building waste, but can also remain in the ground without causing any problems.

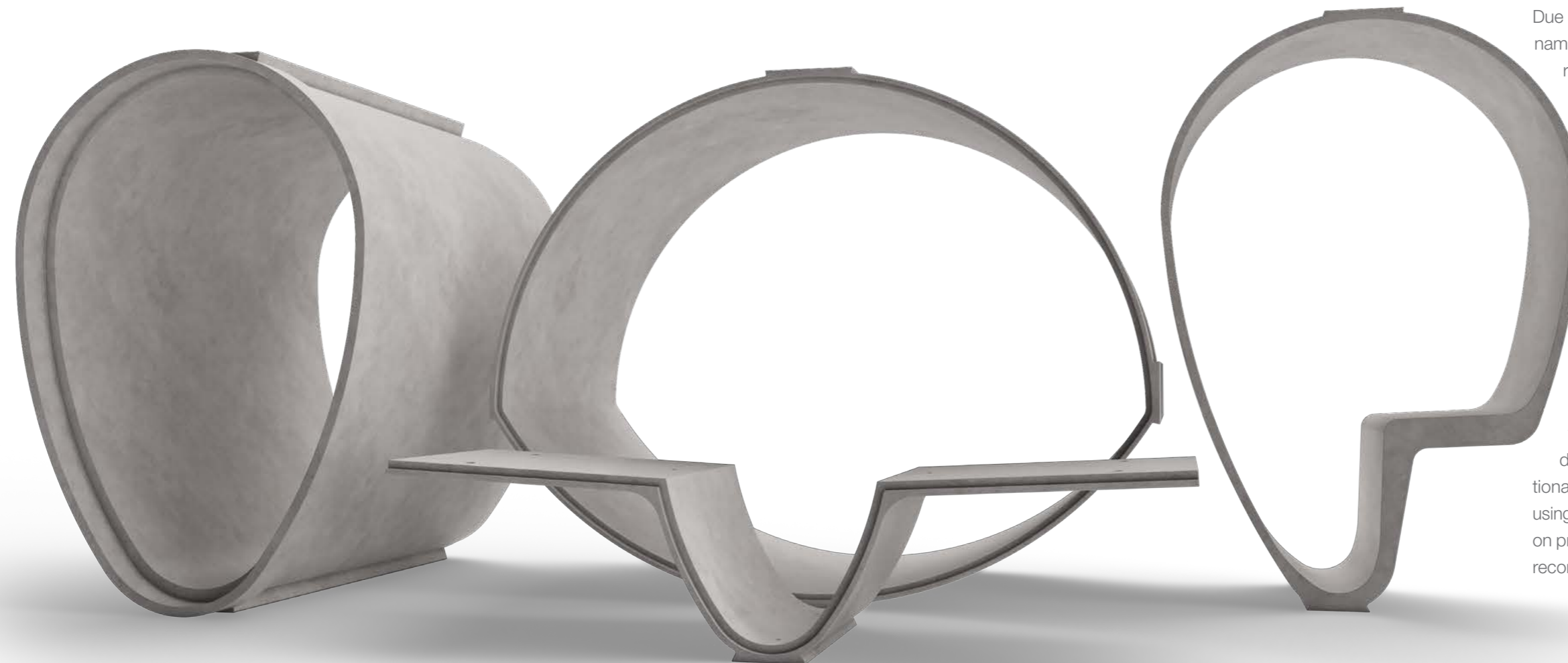

Due to the material's high stability and its static and dynamic elasticity, DURA.PC elements can be manufactured with comparatively thin walls. From a technical standpoint, where other solutions are already at their limits, renovation with DURA.PC offers a particularly interesting alternative.

The components are precisely manufactured with a smooth and almost pore-free surface. All forms, cross-sections and wall thicknesses are custom manufactured in accordance with the requirements of the particular project. With our unique manufacturing process, this is also very affordable.

Prefabricated components of the DURA.PC renovation range thus achieve significant cost savings both during installation and in operation – with an exceptionally long service life that can exceed 100 years. When using our DURA.PC system, we will be happy to advise you on profile cross-sections, construction details, installation recommendations and connection designs.

MATERIAL AND PROCESSING

Most DURA.PC elements consist of polyester resin, quartz sand and additives in a fixed mixing ratio. This makes the material particularly hard-wearing.

QUARTZ MATERIAL – 81 %

The mass of our DURA.PC elements is a special mixture of quartz sand, quartz flour and gravel. The mixing ratio of the different grain sizes, proven over many years, results in a smooth and low-porosity surface and also accounts for the exceptional stability of our DURA.PC elements. The mass is completely bound and held together by the added polyester resin.

POLYESTER RESIN – 13 %

By using different resins, we can provide an optimized, individual solution to meet your requirements. In most applications, we use a polyester resin based on orthophthalic acid. For renovations carried out in areas that place extreme demands on the pH value (both acidic and alkaline), we use our highly pH-resistant polyester resin.

ADDITIVE – 6 %

By using certain additives, e.g. limestone or titanium dioxide, we ensure that desired properties such as increased resistance to weathering are enhanced. Additives also give our product its characteristic color.

USAGE RECOMMENDATION

GROUTING

The following products are recommended for grouting:

- Dämmer R (Grouttech)
- Blitzdämmer (Heidelberg Cement)

JOINTS

The following products are recommended for connecting joints:

- Grouttech 4525
- Sikadur 31 CF

PLEASE NOTE!

The recommendations made here may deviate based on project-specific features, such as the presence of groundwater or special structural requirements, and may no longer be valid in such situations.

If you need advice on the use of the appropriate material, please do not hesitate to contact us.

We will be pleased to provide you with the safety data sheets of our products for your individual project.

MANHOLE RENOVATION

EXPLANATION

If the old sewer needs to be renovated, then the manholes and other structures in the system often also need to be renovated. Renovating these structures is becoming an increasingly important task for those responsible for the systems: the various stresses to which the manholes and shaft structures are subjected – aggressive wastewater, groundwater, earth pressure and traffic, for example – have continually increased in recent years. In some cases, materials once considered reliable and long-lasting are no longer able to withstand modern-day stresses. The consequences are often massive damage to the substance. The most notable damage includes:

- hydrogen sulfide corrosion
- defective step irons
- leaks at joints and in the manhole wall
- cracks and holes
- defective berms and channels

Shafts that show this kind of damage can no longer properly perform their function and have to be repaired. For all standard manholes, the DURA.PC-System offers a suitable and long-lasting solution for channels, berms and manhole walls. Inlets are professionally integrated

at any point in the manhole using standard renovation techniques and complex channel forms are fitted directly on site.

Because all components can be brought in through a standard DN-600 opening, disruptive and expensive earthworks and road construction are avoided; the necessary dewatering can also be reduced to a minimum. The strong connection between the renovation sections and the old manhole means that its structural load-bearing capacity is once again increased.

For the renovation of circular manholes, we use a method successfully employed in tunnel construction for many years: with the lining-segment construction method, the rising manhole rings are lined with three-part elements. The thin walls, made possible because of the material used, are a particular advantage because they allow the maximum amount of space to be preserved (e.g. a DN 1000 shaft after renovation has a clear width of 900). Precision-designed elements are also available for the remaining areas of the shaft.

MANHOLE CHANNEL

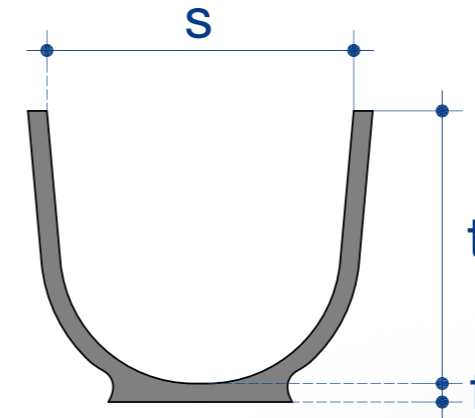

When renovating channels made of in-situ concrete or clinker, the DURA.PC manhole channel ensures a corrosion-resistant and abrasion-resistant channel.

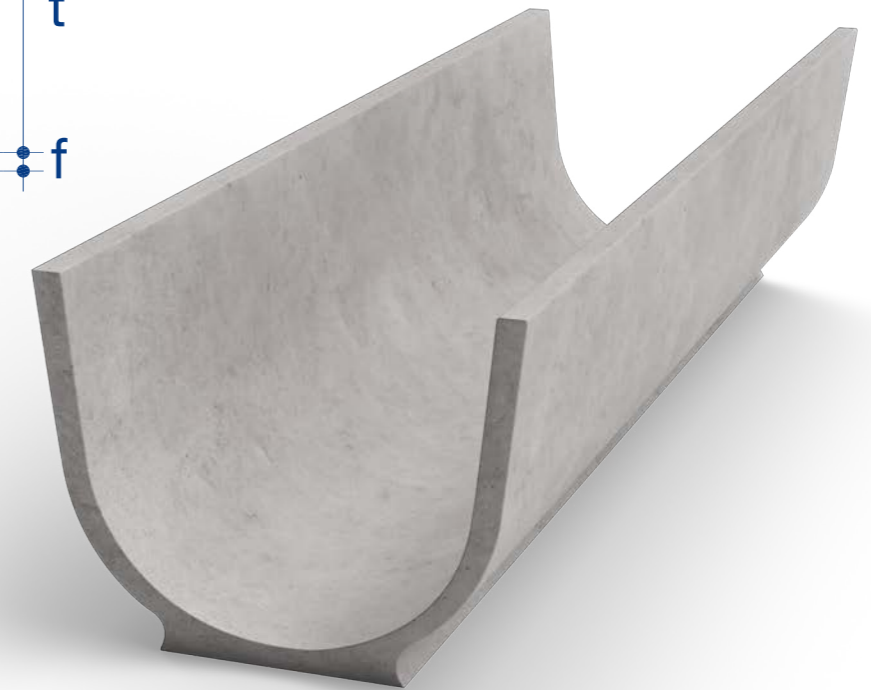

The shaft channel is built into the damaged floor profile. The dove-tail-shaped foot in the sole area ensures secure anchoring in the shaft floor.

STRUCTURE

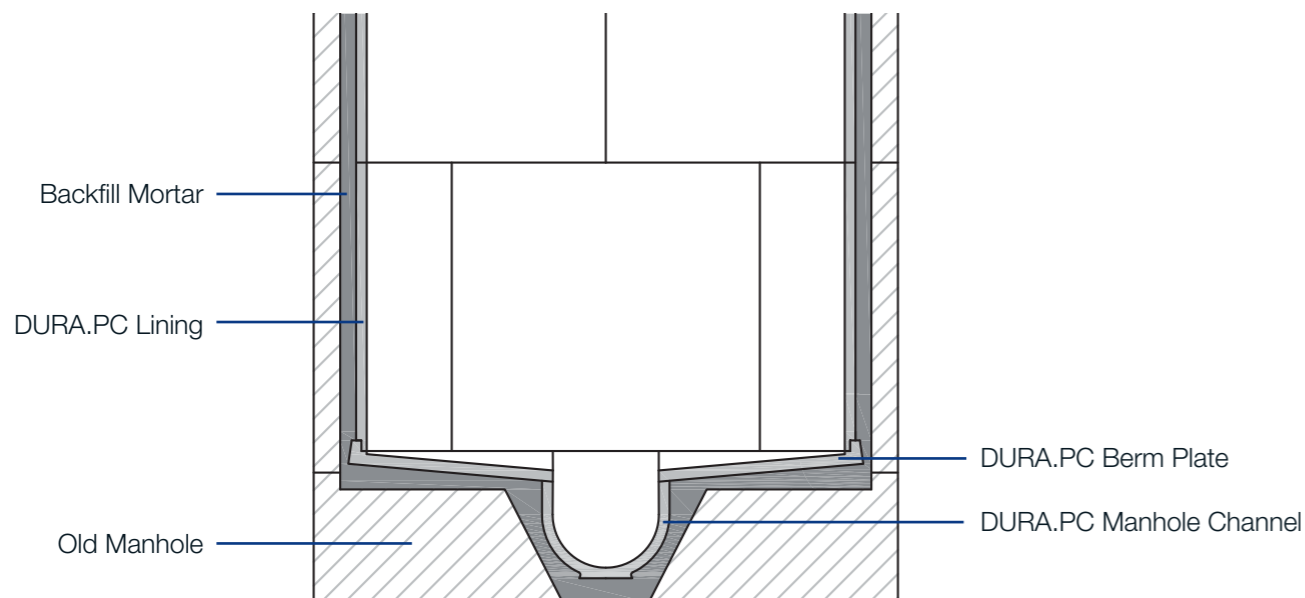

Art. No.	Model	Length	Dimensions in mm			Weight in kg
			s ± 3	t ± 3	f ± 3	
70018849	150	1000	165	145	18	16
70018851	200	930	220	190	20	23
70018850	200	1000	220	190	20	26
70018853	250	920	275	240	20	28
70018852	250	1000	275	240	20	31
70018855	300	900	330	290	20	33
70018854	300	1000	330	290	20	38
70018857	400	860	430	390	20	39
70018856	400	1000	430	390	20	45
70018858	500	1000	540	500	20	60
70018859	600	1000	636	600	22	65

Special lengths and profiles available on request

MANHOLE RENOVATION

MANHOLE BERM PLATES

When renovating cast-in-place concrete or brick berms, we recommend our DURA.PC berm plates for the production of a corrosion-resistant and abrasion-resistant tread surface.

The plates, consisting of two parts, are brought in through the manhole opening. Bonding the plates with the DURA.PC manhole channel and the DURA.PC lining elements creates a watertight and corrosion-resistant manhole substructure.

On request, we can equip the elements with anti-slip surfaces ex works – please contact us for a consultation.

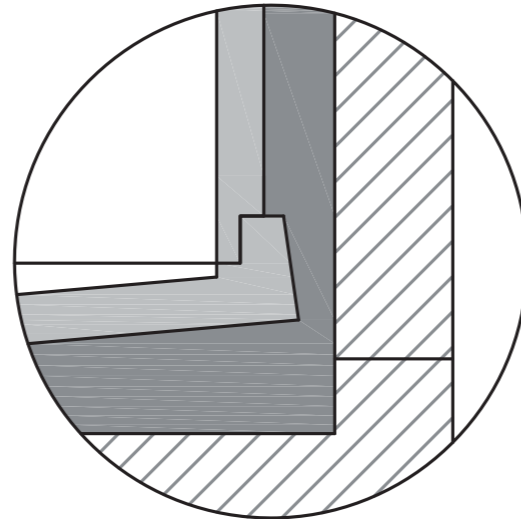
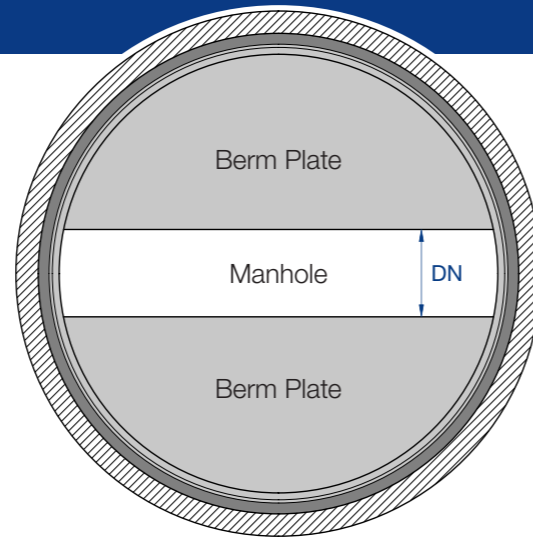

Art. No.	Channel DN	Wall thickness dimensions in mm b ± 3	Weight in kg
for manholes DN 1000 with straight passage (berm plate)			
70018860	150	20	12
70018861	200	20	12
70018862	250	20	11
70018863	300	20	10
70018864	400	20	9
70018865	500	20	8
70018866	600	20	7
for manholes without a channel			
70018848	–	20	19

Special lengths, profiles and corresponding anti-slip classes in accordance with DIN 51130 available on request

LINING

For the renovation of cast-in-place concrete manholes, our DURA.PC lining segments for the construction of a corrosion-resistant and abrasion-resistant shaft lining have proven their worth.

The three-part lining segments are brought in through the manhole opening without first having to undertake complex disassembly of the taper from the manhole.

The lining segments are joined to both the berm plates and the taper with rebate joints.

Your manholes aren't completely circular? DURA.PC also offers a solution for this. We are happy to advise you when it comes to choosing the optimal solution for your renovation project.

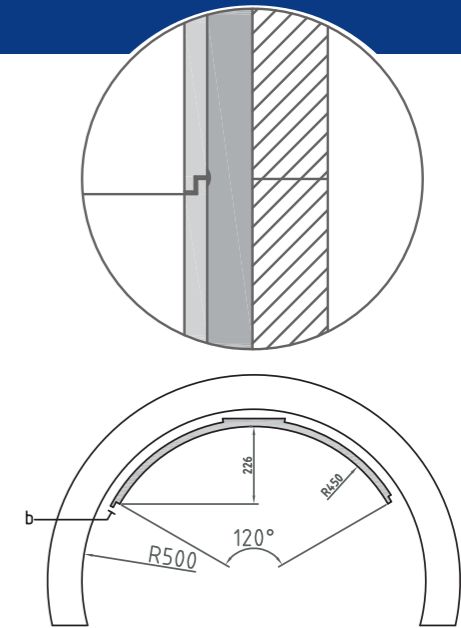

Art.-Nr.	Model	Dimensions in mm		
		r ± 3	b ± 3	Höhe ± 3
70018913	DN 1000	450	20	500
70018914	DN 1000	450	20	250
70021453	DN 1000	450	20	100

Other heights and sizes up to DN 2400 are available on request

TAPER ELEMENT

A special four-part element for lining the taper completes our system.

As with the other parts of our system, the elements are brought in through the manhole opening. They use rebate joints to ensure a secure connection with the uppermost row of lining segments.

On request, we can equip the elements ex works with countersunk holes for fastening the elements to the existing structure – please contact us for a consultation.

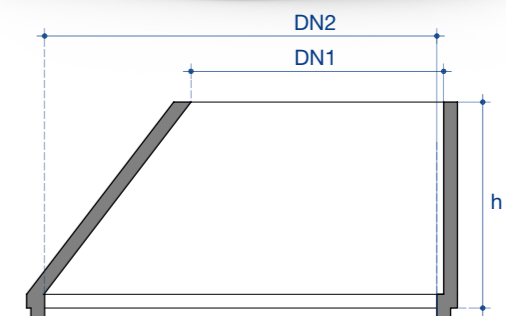
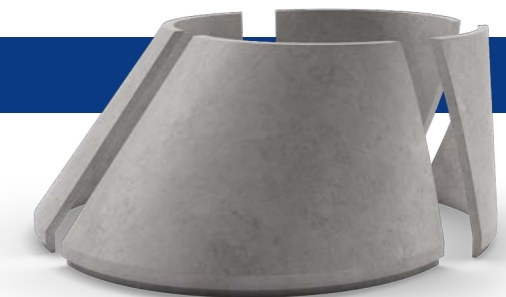

Art. No.	Description	Dimensions in mm			Weight in kg
		DN1	DN2	h	
70021454	Taper 900/600 (4-part)	600	900	472	86

In combination with lining type DN 1000

PARTIAL SEWER RENOVATION

EXPLANATION

If a sewer only shows damage in the invert or arch area, complete renovation does not always make good economic sense. For accessible channels, pipe-segment lining is frequently used as a renovation technology for damage in these areas.

If the invert area is damaged, the sewer invert in need of renovation is lined with stable, corrosion-proof shells. If the lateral berms also need to be renovated, it makes no difference for our system whether right angles or acute angles occur in the transition from the channel to the berm. The renovation profiles are only joined together permanently and waterproof bonded once they are in

the channel. The advantage: even in situations where large assembly pits can't be dug, the system can easily be employed.

With project-specific installation aids, bonding in the arch area during a renovation is also straightforward and offers a secure solution for connecting the individual components. For different sewer profiles, you can use a variety of components to suit your particular application – or develop with us a completely new, customized form to suit your project.

HALF SHELL (BUTT JOINTED)

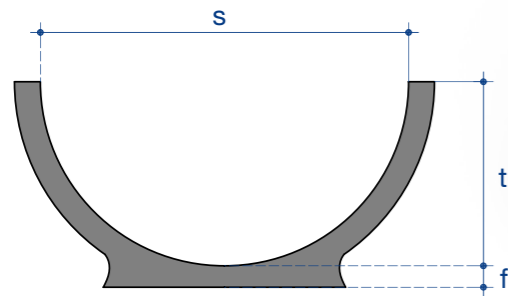

Art. No.	Model	Length	Dimensions in mm			Weight in kg	Pieces per pallet	
			BxH	L (mm)	s ± 3			t ± 3
70018809	150/75	1000		150	75	20	13	50
70018808	200/100	1000		200	100	20	20	40
70018807	250/125	1000		250	125	20	20	30
70018806	300/150	1000		300	150	20	21	27
70018810	350/175	1000		350	175	20	30	24
70018802	400/200	1000		400	200	20	30	16
70018801	500/250	1000		500	250	20	46	14
70018803	600/300	1000		600	300	22	50	9
70018830	700/350	1000		700	350	20	54	7
70018804	800/400	1000		800	400	22	63	7
70018805	1000/500	1000		1000	500	22	72	3

Special lengths and profiles available on request

ELONGATED SECTION CHANNEL

The DURA.PC section channel, in standard 1m lengths, is used for the corrosion-resistant lining of the channels of egg-shaped sewers that use cast-in-place concrete construction. With these components, you will ensure fast construction progress. In connection with standard lining systems (e.g. pneumatic lining, steel lining), a high-

quality channel surface is achieved with an economical construction method.

Compared to conventional channel linings, the proportion of joints per surface area is reduced by up to 80% with DURA.PC section channels.

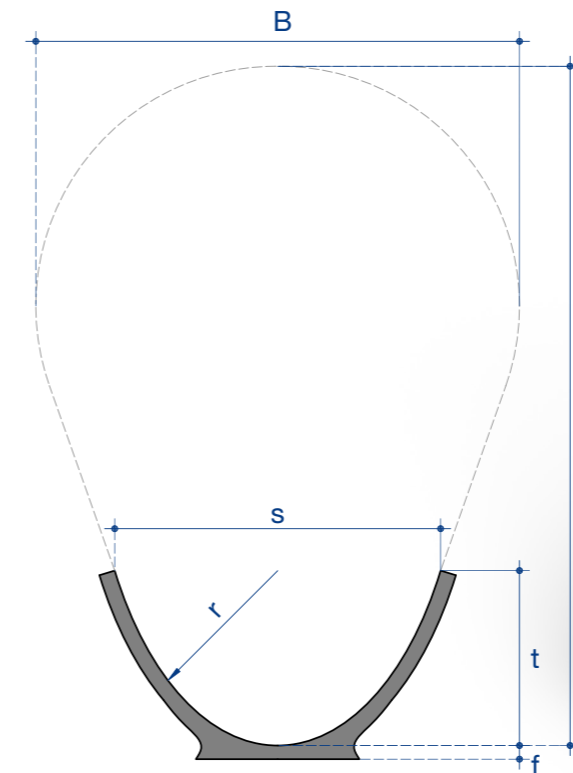

Art. No.	Model	Length	Dimensions in mm				Weight in kg	Pieces per pallet	
			B x H	L (mm)	r ± 3	s ± 3			t ± 3
70018811	400/600	1000		100	350	228	18	23	36
70018813	500/750	1000		125	410	245	18	27	27
70018815	600/900	1000		150	460	248	18	28	30
70018817	700/1050	1000		175	507	260	18	31	18
70018819	800/1200	1000		200	554	271	18	35	18
70018821	900/1350	1000		225	602	282	18	40	16
70018823	1000/1500	1000		250	650	293	18	37	18
70018825	1200/1800	1000		300	809	311	20	36	20
70018829	1400/2100	1000		350	950	320	20	40	18

Special lengths and profiles available on request

PARTIAL SEWER RENOVATION

ONE-THIRD SECTION CHANNEL WITH FOOT

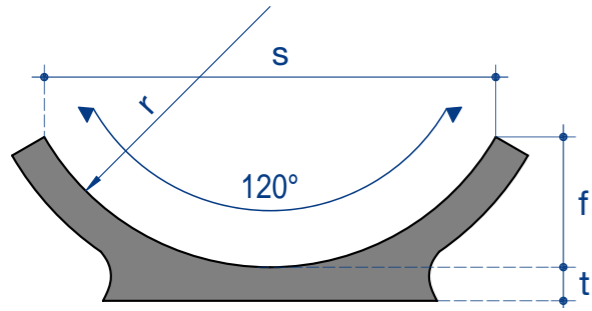

The DURA.PC section channel with foot is used as a corrosion-resistant and abrasion-resistant lining of the dry-weather channel for different channel cross-sections. With the standard 1.0m length of the section channels, the proportion of joints in the lining is drastically reduced.



Art. No.	Model	Length	Dimensions in mm				Weight in kg	Pieces per pallet
			L (mm)	r ± 3	s ± 3	t ± 3		
70018812	400/600	1000	100	175	55	18	12	60
70018814	500/750	1000	125	217	63	18	16	60
70018816	600/900	1000	150	260	75	18	17	60
70018818	700/1050	1000	175	303	88	18	20	36
70018820	800/1200	1000	200	346	100	18	24	36
70018822	900/1350	1000	225	390	113	18	30	28
70018824	1000/1500	1000	250	433	125	18	36	32
70018828	1100/1650	1000	275	476	138	35	53	14
70018826	1200/1800	1000	300	520	150	22	36	24
70018827	1400/2100	1000	350	606	175	22	40	18

Special lengths and profiles available on request

ONE-THIRD SECTION CHANNEL WITHOUT FOOT

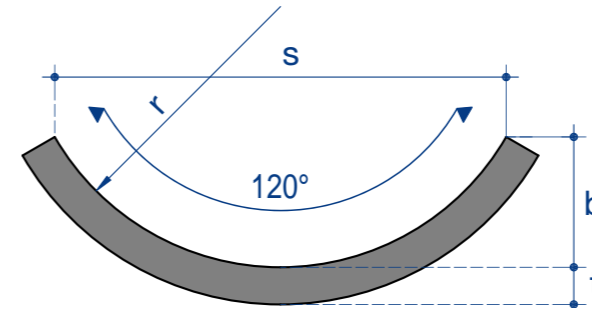

The DURA.PC section channel without foot is used in sewer conversions and repairs. The components have a sandblasted back, ensuring optimal binding with the mortar bed. One-third channels are primarily used in connection with DURA.PC wall panels.

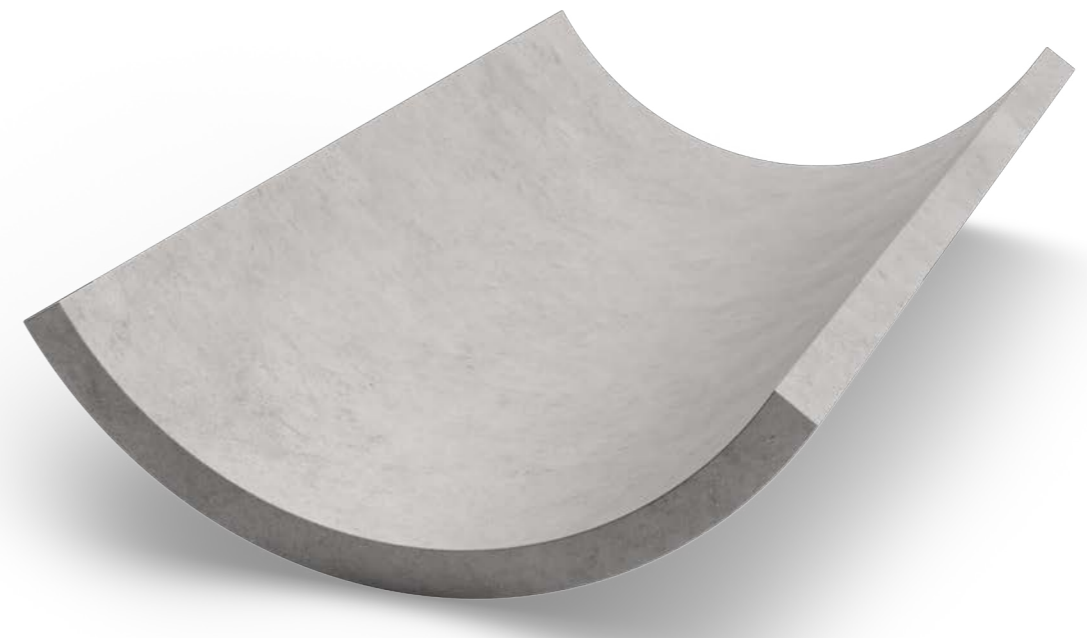

Art. No.	Model	Length	Dimensions in mm				Weight in kg	Pieces per pallet
			L (mm)	r ± 3	s ± 3	t ± 3		
70018791	400/600	495	100	173	50	18	5	100
70018792	500/750	495	125	217	63	18	6	100
70018793	600/900	495	150	260	75	18	7	100
70018794	700/1050	495	175	303	87	18	8	80
70018795	800/1200	495	200	346	100	18	10	60
70018796	900/1350	495	225	390	113	18	13	52
70018797	1000/1500	495	250	433	125	20	14	44
70018800	1100/1650	495	275	476	138	35	24	30
70018798	1200/1800	495	300	520	150	22	18	36
70018799	1400/2100	495	350	606	175	22	18,5	36

Special lengths and profiles available on request

PARTIAL SEWER RENOVATION

ONE-THIRD SECTION CHANNEL WITH FOOT

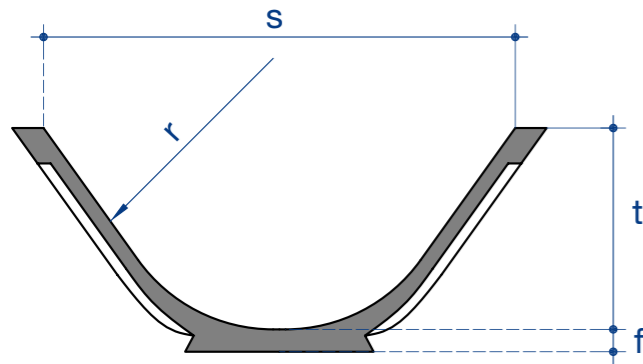

The DURA.PC section channel with foot is used as a corrosion-resistant and abrasion-resistant lining of the dry-weather channel for different channel cross-sections. With the standard 1.0m length of the section channels, the proportion of joints in the lining is drastically reduced.



Art. No.	Model	Length	Dimensions in mm				Weight in kg	Pieces per pallet
			L (mm)	s ± 3	r ± 3	t ± 3		
70018831	500/750	1500	410	125	245	30	51	17
70018837	600/900	1500	460	150	248	34	49	16
70018833	700/1050	1500	507	175	262	34	51	12
70018832	800/1200	1500	554	200	271	34	58	14
70018835	900/1350	1500	602	225	282	34	59	12
70018834	1000/1500	1500	584	250	237	34	55	14
70018836	1200/1800	1500	609	300	211	34	56	14

Special lengths and profiles available on request

WANDPLATTE

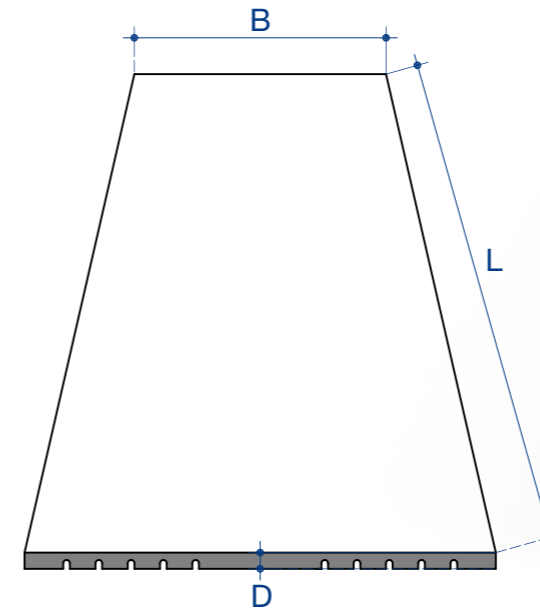

Wall panels are used for sewer conversions and repairs. The back of the DURA.PC wall panels are grooved and undercut to ensure secure anchoring in the mortar bed.



On request, DURA.PC wall panels can be supplied with a sandblasted or sanded back. Wall panels can also be used in combination with DURA.PC one-third sections

and also for lining shafts and structures in residential water management.

SPECIAL DESIGN: WALL PANEL WITH THROAT DESIGN ON REQUEST

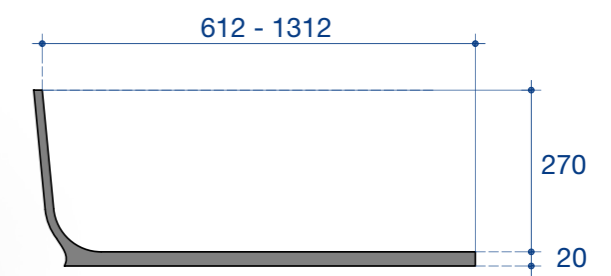

Art. No.	Model	Dimensions in mm		Weight in kg	Pieces per pallet	
		L x B x D	L ± 3			B ± 3
70018786	500/200/20 genutet		500	200	4	200
70018788	500/400/20 genutet		500	400	8	80
70018787	1000/200/20 genutet		1000	200	8	80
70018789	1000/400/20 genutet		1000	400	16	40
70018790	1000/450/20 genutet		1000	450	20	20

Special lengths and profiles available on request; Specially acid-resistant panels available on request

COMPLETE RENOVATION

COMPLETE PIPE SECTIONS

For damage occurring over a large area, as well as for an accumulation of damage in many areas of a sewer, a complete renovation is the logical consequence. Depending on the particular profile shape and accessibility on the future construction site – as with partial lining – the work can be executed using pipe-segment lining with on-site bonding. Alternatively, renovation can also be carried out using single-pipe lining.

For renovations involving the single-pipe method, the DURA.PC complete pipe sections are provided ready for installation ex works. For pipe-segment lining we provide multi-part profiles. After successful installation in the old sewer, these form, as an extremely resistant

inner lining, the new inner wall of the sewer.

Depending on the requirements and constraints of the particular installation, the components are either butt-jointed together in the sewer or joined by means of a seam joint. The elements are bonded together with epoxy resin.

The annular space created in both processes is then backfilled in sections and layers with a special pumpable mortar. In this way, a new sewer-within-a-sewer is created in just a few steps, with a service life comparable to that of a brand new sewer.

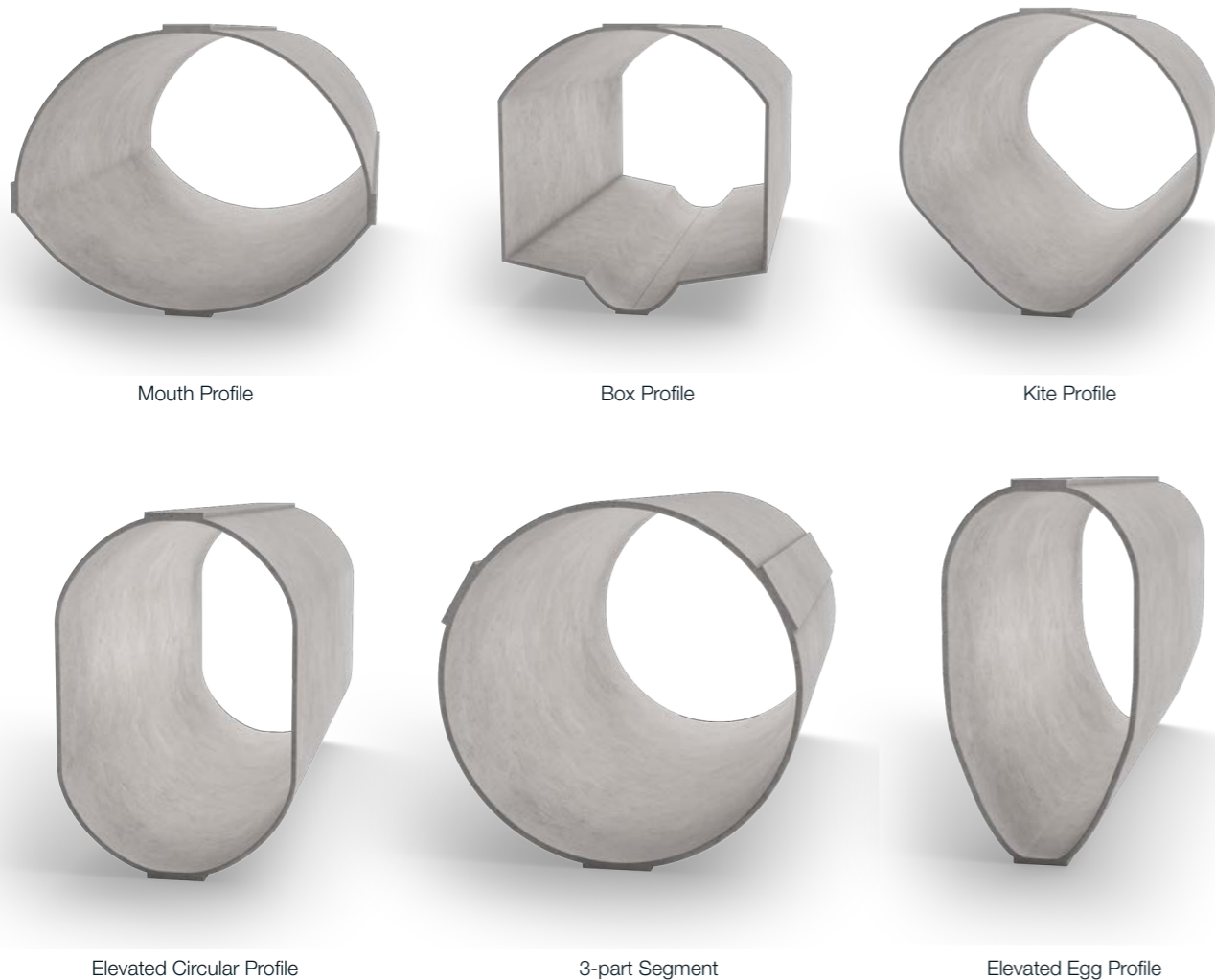

Mouth Profile

Box Profile

Kite Profile

Elevated Circular Profile

3-part Segment

Elevated Egg Profile

TAILORED FOR ANY REQUIREMENTS

For lining large sewers, we list below some typical DURA.PC profile types. Because the system is tailored to your specific requirements, almost any conceivable

profile form is possible. The process-related reduction in pipe cross-section is thus kept to a minimum.

TECHNICAL STANDARDS AND GUIDELINES

For pipe-segment lining, we recommend following the procedure as stipulated in DIN EN 15885: "Classification and characteristics of techniques for the renovation, repair and replacement of drains and sewers" and DWA bulletin 143-4: "Installation procedures (pipe-segment lining) for accessible wastewater pipes, sewers and structures."

For single-pipe lining, we recommend using DIN EN 15885 or DWA bulletin 143-12: "Renovation of wastewater pipes and sewers with prefabricated pipes with and without individual annular-space procedures."

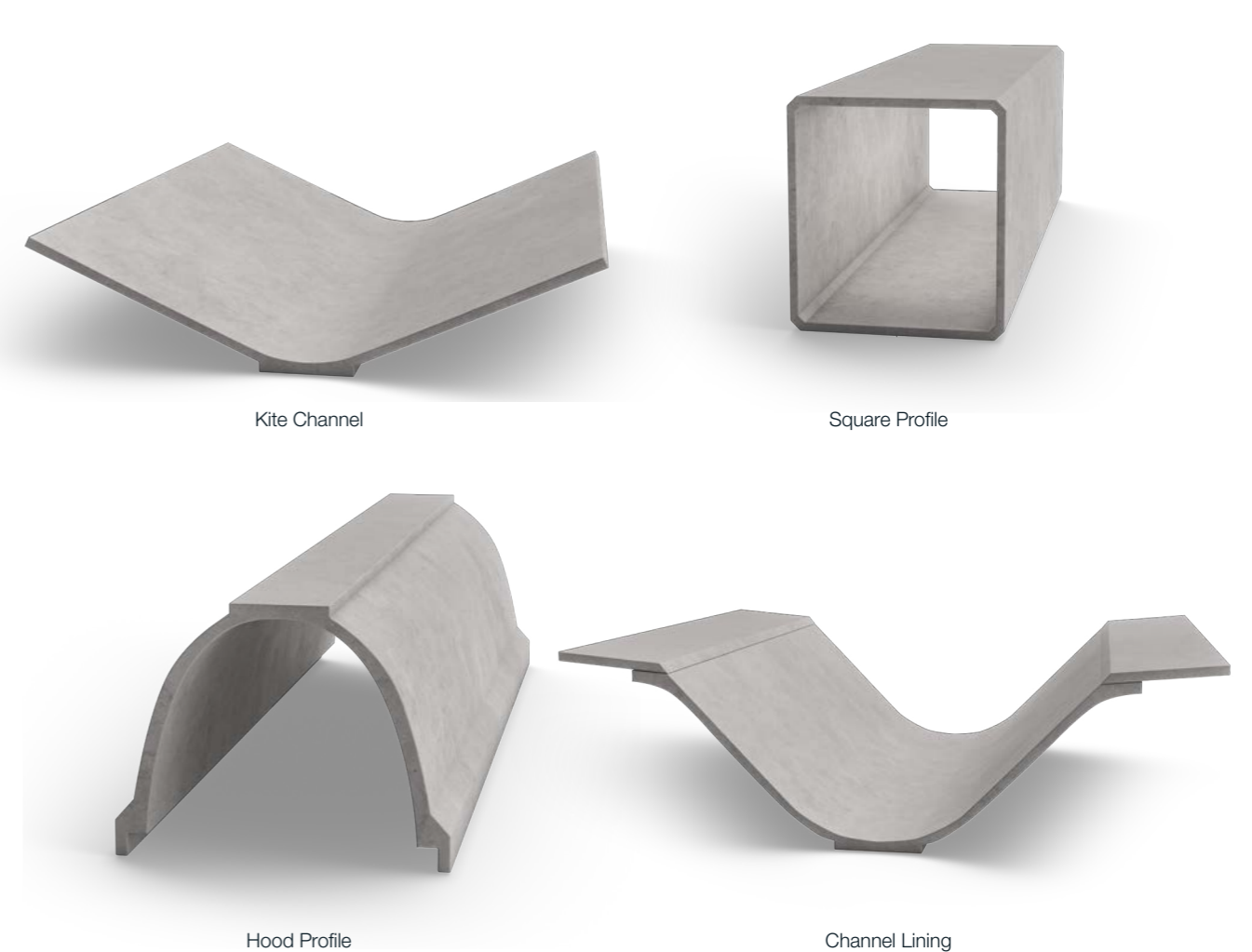

Kite Channel

Square Profile

Hood Profile

Channel Lining

TWO EXAMPLES

Two successful examples stand for the large number of projects we have carried out in partnership with our customers: the renovation of the main sewer in Arnhem in the Netherlands, and the renewal of a sewer line in Zelzate, Belgium.

ARNHEIM

FIRST-CLASS RENOVATION OF 150-YEAR-OLD MAIN SEWER

Some people call it „Arnhem’s biggest structure“: Almost 150 years ago, the approximately 1.5 km long main sewer known as the „Moerriool“ was built using a special profile comprising a triple-layer brick arch construction coupled with a dry weather channel with shoulders made of non-reinforced concrete. The sewer passes beneath the entire historic old town.

When this was to be renewed in 2018 as part of a far-reaching renovation project, it quickly became clear that the location – in the heart of Arnhem’s inner city – ruled out an open renovation of the main sewer. The disturbance to local residents, business people, tourists and daily traffic would have been too great.

A solution had to be found that avoided any earthworks – and it had to be both stable and long-lasting. At no point was the renovation to endanger either people or historical structures.

The municipality of Arnhem carried out the project together with construction company Van der Ven and civil engineering firm Kumpen – and chose the DURA.PC system from Steinzeug-Keramo. Durability and robustness were key factors. However, the flexibility of the system was perhaps the decisive reason for the choice: the sewer profile does not follow a fixed geometry and therefore required a customized solution that could be introduced into the sewer even with the very tight access available.

The project was realized in two stages using advanced laser scanning and radar technology alongside classical inspection technology before the elements were installed. The result also convinced the experts in the trade, with the project winning the NSTT No-Dig Award 2018 thanks to the innovative techniques employed and the outstanding execution of the project.

The city of Arnhem decided to continue with the solution DURA for the second renovation phase in 2020.



Before

After

ZELZATE

STRUCTURALLY DEMANDING SEWER ROUTING MASTERED

During the renovation of an approximately thirty-meter section of a sewer in Zelzate, Belgium, between Ghent and Antwerp, it was already clear to all parties involved, even during the planning phase, that the usual renovation methods would not get very far. CIPP and coating methods, otherwise commonly used in such cases, were not suitable due to the demanding geometry and the condition of the old pipe. The project engineers found the appropriate solution in the DURA.PC renovation solution.

The specific challenge was that the old sewer was made of concrete with a 700 x 1100 mm box profile. This meant high demands on the statics of the profile to be renovated. In addition, there were local peculiarities: the Flemish marsh soil with its tendencies toward buoyancy and only a small amount of cover atop the sewer.

The renovation was carried out using single-pipe lining. A preliminary calculation using the FE-method reassured

the client that the statics were being taken into account at every phase of construction. Also, throughout the entire process, our experts were on hand to advise the construction company carrying out the job, as filling the annular space turned out to be a demanding task.

We came up with a special trick to solve the challenge of getting the elements into the existing sewer: we set up a rail system that allowed the individual custom-made elements to be taken to their final position quickly and easily.



INDIVIDUAL SOLUTIONS

FROM PRODUCTION TO CONSTRUCTION SITE



COMPREHENSIVE CONSULTATION

As a Europe-wide supplier of complete solutions and systems for the water and wastewater industry, Steinzeug-Keramo also specializes in the customized partial or complete renovation of accessible sewers and manholes. Our experts put their experience at your disposal, supporting you with optimal planning and execution of your projects – from design to completion.



INDIVIDUAL PRODUCTION

With technical expertise and a spirit of innovation, our specialists have developed a consistently proven, modular system that can be individually expanded at any time. The individual construction elements are part of a complete and well thought-out technical solution for the renovation and retrofitting of accessible sewer systems. Design and manufacture are part of our service; in general we see ourselves as a fully integrated partner and flexible problem solver for your construction projects.



STRAIGHTFORWARD INSTALLATION

Our system of high-precision components, like our comprehensive service and consultation, has proven itself on numerous construction sites. The work progresses rapidly, and every process step is accurately documented. We supply all necessary supplementary materials and operating resources, such as multi-component adhesives and special tools to make the work easier. If required, we also offer individually tailored instructions for complex projects.



SUSTAINABLE RESULTS

DURA.PC elements are made of waterproof polymer concrete, the ideal material for reliably watertight sewer components. With a reliably predicted service life of 100+ years, DURA.PC elements ensure both ecological and economic sustainability. The renovated and retrofitted structures gain trouble-free, environmentally safe functionality for the long term, making them essential elements of a municipal infrastructure geared towards quality of life.

MATERIAL CHARACTERISTICS

Compressive strength:	> 80 N/mm ²
Flexural strength:	> 20 N/mm ²
Elastic modulus:	18.000 N/mm ²
Abrasion resistance:	0.14 mm per 100,000 cycles (Darmstadt method)
Chem. resistance:	According to resistance list
Temp. Resistance:	Sustained temperature resistance to 80°C
Moisture absorption:	< 0,13 percent by weight
Water penetration depth:	0 mm
Mass loss pH 14 (1-molar NaOH):	0,20 %
Mass loss pH 1 (0,5-molar H ₂ SO ₄):	0,17 %
Fire protection class:	B1 (fire resistant) *
Fire index:	5.2 (fire resistant) **

* applies for standard polyester resin
** applies for ISO-NPG resin

STANDARDS

ÖNORM EN 15564:	Precast concrete products - Resin bound concrete - Requirements and test methods
EN 1504-4:	Products and systems for the protection and repair of concrete structures - definitions, requirements, quality control monitoring and evaluation of conformity Part 4: Adhesives for structures

If your project reaches the boundaries of the technical data provided, please do not hesitate to contact us. We will do our best to find a solution to match your needs.

Do you have a specific project in mind? We would be happy to put our expertise to work to support you in this area as well. We are there for you – from the initial concept to the planning process and construction.



See the DURA.PC installation possibilities for yourself on YouTube.



DURA.PC AT A GLANCE

- ✓ When extremely long service life is a mission-critical factor.
- ✓ When your construction demands highly flexible geometry of the individual components.
- ✓ When being reliably watertight is top priority on your projects.
- ✓ When perfect dimensional stability under heavy loads is a must.
- ✓ When access to the sewer is tight.
- ✓ When you need sustained abrasion resistance under constant stress.
- ✓ When you have to ensure long-term, high-level chemical resistance.
- ✓ When frost and heat resistance are part of your project's specifications.
- ✓ When you expect uniform wall structure and the highest level of precision in your components.
- ✓ Our experts are happy to inform you about the strengths and opportunities offered by the DURA.PC system.

Get in touch!

Our team is at your disposal for technical advice.

Customer Service: +49 2234 507-507

www.steinzeug-keramo.com